

Classic Collection



Wilde + Spieth

4	Lookbook
32	Components of a Classic
38	References
42	Product Overview
46	Product Variants
48	Colours & Wood Veneers
49	Textiles
50	Product Details
52	Specifications
54	Imprint

Welcome to Wilde + Spieth. At the centre of our universe stands that most humble and essential of objects: the chair. To us, the chair extends an invitation—to ground oneself within the present environment, whether gathering around a table to exchange ideas or share a meal or engaging in a moment of contemplative solitude.

Across countless settings and occasions, Wilde + Spieth's Classic Collection has for decades extended an ongoing invitation to the architects, interior designers, and discerning individuals with whom our approach continues to resonate: a bid to further a quiet legacy anchored in progressive design values, uncompromising craftsmanship, and a commitment to caring—about quality, responsible production, and longevity.

From our world to yours, this catalogue presents this twofold invitation that lies at the heart of what we do: to immerse yourself in our story, our designs, and our product details—so that you might find your vision and requirements reflected within them, just as Egon Eiermann himself did decades ago.

We warmly invite you to take a seat with us.

SE 68 Multi Purpose Chair
light grey, rosé, graphite,
yellow, black, cobalt blue,
blood orange, beech
with black frame



SE 68 Multi Purpose Chair
graphite, rosé, light grey, black
with black frame



SE 18 Folding Chair
black



SB 38 Bar Stool
black with black frame



SE 42 3-Legged Chair
black

SE 18 Folding Chair
beech



SE 68 Multi Purpose Chair
rosé with chrome frame

SE 68 Multi Purpose Chair
black with black frame





SBG 197 R Swivel Chair
Oak with chrome frame



SB 38 Bar Stool
black with black frame

S 197 R 20 Swivel Chair
black with black frame



S 38 S/1 Stackable Stool
black with black frame



SE 68 Multi Purpose Chair
black with black frame
with upholstery



SE 68 Multi Purpose Chair
cobalt blue, beech
with black frame

SE 68 Multi Purpose Chair
black, beech, cobalt blue
with black frame



SB 68 Bar Chair
black with black frame



S 197 R20 Swivel Chair
black with black frame



SE 68 Multi Purpose Chair
white with chrome frame



S 38 S/1 Stackable Stool,
SB 38 Bar Stool,
SE 68 Multi Purpose Chair
white with chrome frame

SE 68 Multi Purpose Chair
black with black frame

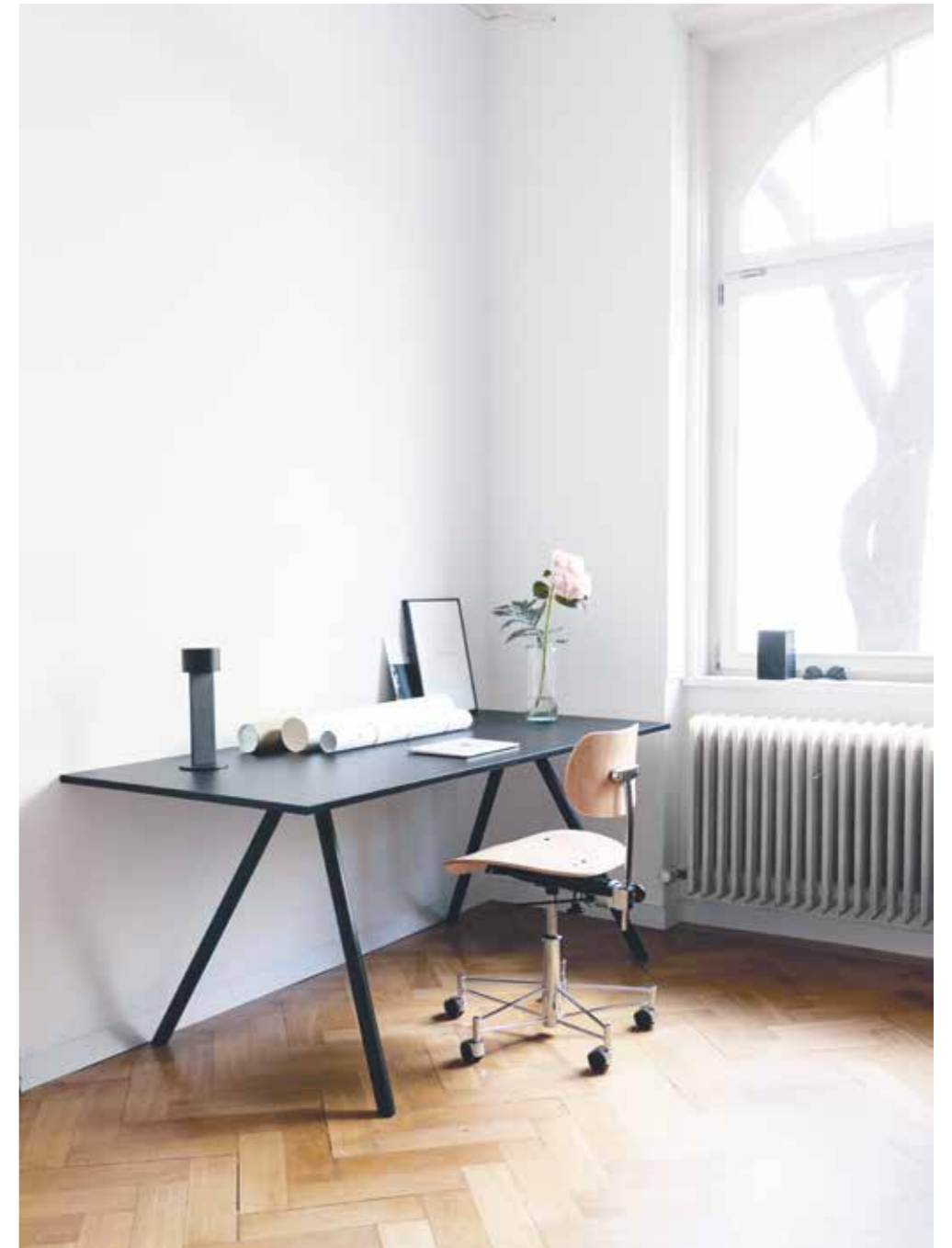

SBG 197 R Swivel Chair
beech with chrome frame



SE 42 3-Legged Chair
beech



SE 68 Multi Purpose Chair
oak with black frame

SE 68 Multi Purpose Chair
black, beech
with black frame



Components of a Classic

- 1 The Wilde + Spieth brochure "Formstühle" from the 1950s showing the SE 18 folding chair on the cover.
- 2 The German pavilion at the World Exhibition in Brussels, Belgium, 1958.
- 3 Egon Eiermann at the drawing table.



1



2

What does it take to be timeless? Throughout our near-two centuries-long history, consistency—of production, aesthetics, and above all, quality—has been both our motivation and our objective. Across each decade's ebbs and flows, we'd like to think it's consistency that has allowed us to forge alliances with the world's foremost architects, and that has earned our furniture its status among modern classics. While our story evolves, our impetus remains the same: to produce chairs of high-calibre comfort and understated elegance for a lifetime. A reflection on the components that enable us to do so follows.

Long-standing Tradition

Baden-Württemberg, 1831. The carpentry workshop Schreinerei Spieth was founded amidst the rich craft heritage of the Medieval town of Esslingen on the Neckar River. In 1912, Mr. Wilde joined the business, and the newly-formed Wilde + Spieth moved into roller shutter construction: a fortuitous undertaking, as the quality of the shutters gained the attention of pioneering German architect Egon Eiermann, who

incorporated them into his domestic constructions and renovations. A flourishing partnership ensued, and in 1948, Eiermann's need for durable, affordable furniture for his social housing construction led him to propose a joint venture in furniture production. The moment was a pivotal one in the history of Wilde + Spieth, giving us a clarity of purpose that has since remained steadfast.

Trusted Partnership

Founded on shared values and complementary strengths, our partnership with Egon Eiermann was driven by a mutual appreciation for functional aesthetics, uncompromising precision and a dedication to perfectionism. The visionary architect provided the design ingenuity; we offered our expertise in craft and finely-tuned production techniques. The result, forged over a two-year-long process of experimentation in material and form, marked a breakthrough in the history of chair design: a seat and back made from pressed beech plywood and contoured to the human form for optimal sitting comfort.

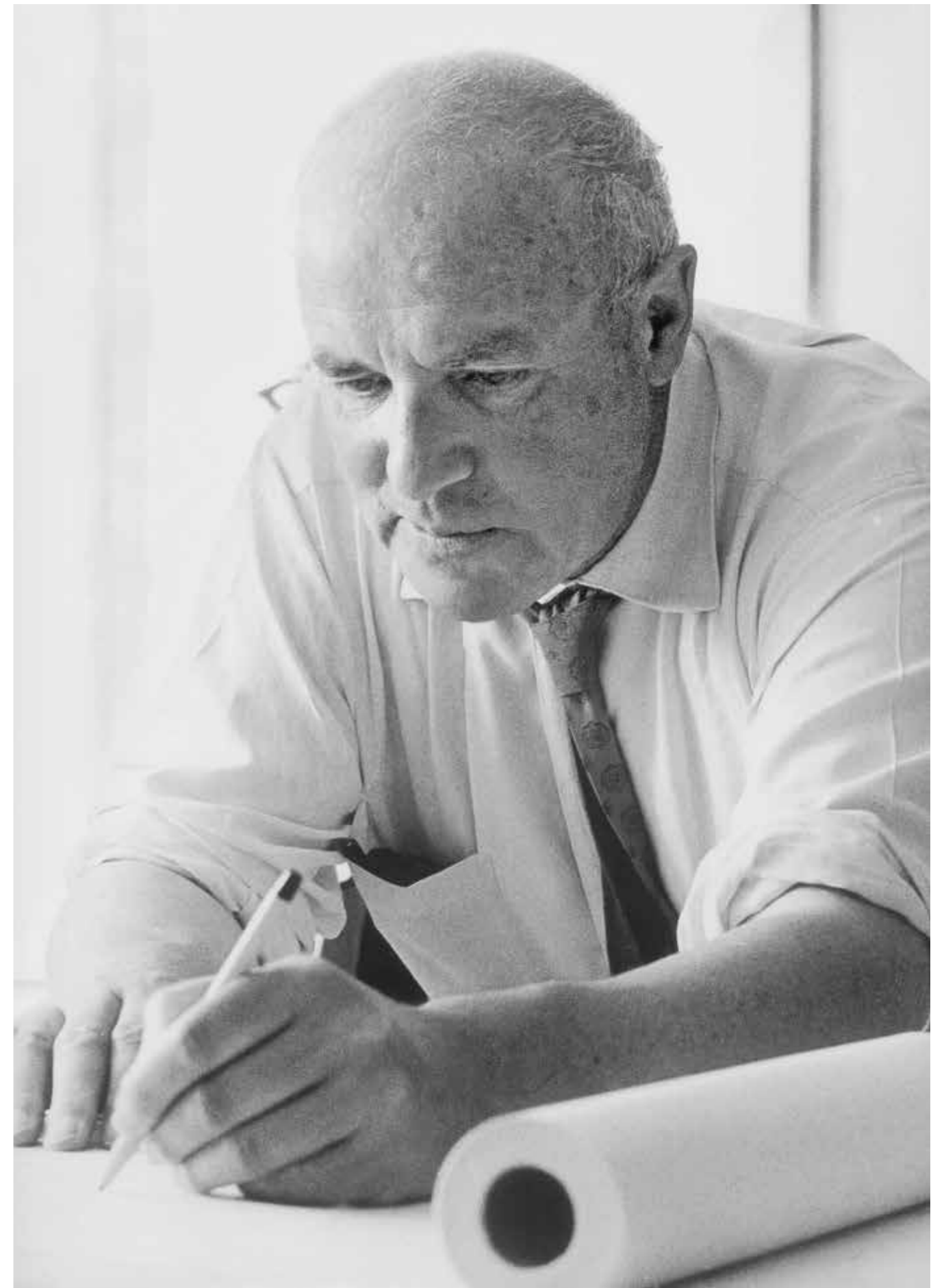

3



The seats of the SE 68 chair consist of 9 layers of beech veneer glued together and then pressed into shape. For every tree we use for our furniture, a new tree is planted. We're resolute in our belief that our world and our environment is a shared responsibility.



1

- 1 The assembly of the seat and the backrest is the final step in the manufacturing process.
- 2 Furniture with a long lifespan is created with skill and care.
- 3 Dimensioning of an SE 68 SU seat. Consistent design for over 70 years.
- 4 The SE 42 three-legged chair from 1949 was originally intended as flat pack furniture.



2



4



3

The development was met with such acclaim that it formed the base of 30 distinct designs over the following two decades. Each variation caters to specific requirements—from stack- and foldability to swivel functionality and bar stools—yet was unmistakably emblematic of the heightened function and pure form underpinning the collaboration that created it.

Meticulous Craftsmanship

Reverence for the natural properties of our materials has always guided our production methods. In the 1950s, plywood was rarely used in the German market, so we started to work with it from scratch, creating our chair moulds and prototypes—along with the technology required to produce them—ourselves. Today, the niche scale of our production has led us to entrust leading local specialists with our manufacturing, allowing us the flexibility to fulfil custom colour, coating, and functionality requests while ensuring the uncompromising quality of the ‘Made in Germany’ seal remains true. Environmental responsibility is integral to every step

of our process: durability is ingrained in each chair’s design, and further ensured by our commitment to first-grade materials. For every tree that becomes a Wilde + Spieth chair, another is planted—meaning that the forest from which we source our wood has remained the same size ever since 1870.

Designed to Endure

Simplicity, balance, universality: the priorities shared by Wilde + Spieth and Egon Eiermann have resulted in silhouettes and materials that seamlessly adapt to their surroundings as well today as they did in the 1950s. Today, we’re proud to focus on essentials that have stood the test of time: a refined range of icons that bridge the modern with the contemporary. Free of extraneous elements, the reduced forms of the chairs—and two tables—in our Classic Collection serve as ideal canvases for subtle updates that reflect present aesthetic preferences. A wide range of bespoke finish options, from matte powder-coated steel to natural wood finishes, enable the ongoing relevance of a classic within the zeitgeist, time and time again.

References

Furniture's true quality reveals itself within its surroundings – in its interplay with the dimensions of architecture, nearby objects, and the intangible feeling that lends a certain constellation its enticing atmosphere. Enabling a dialogue between the elements of a room in pursuit of spatial harmony is a core tenet of our design philosophy.

The clean, gently curving forms that have characterised the Wilde + Spieth Classic Collection since its inception in the 1950s enables our chairs to integrate into a wide range of spaces, from neat rows of the SE 68 Multi-Purpose Chair bringing to life a revered cultural institution, or the considered placement of a single SE 42 3-Legged Chair in a cosy living room.

Universality equally lends our chairs the advantage of customisation. From natural finishes to progressive tones and bespoke upholstery, we are pleased to offer myriad possibilities for personalisation, further ensuring the optimal fit of our designs into your spaces.

Sonnesgade 11
Location: Aarhus, Denmark
Space: Restaurant
Products: SE 68 Multipurpose Chair



VOR Studio
Location: Munich, Germany
Space: Studio and Showroom
Products: SE 42 3-Legged Chair

Mono
Location: Darmstadt, Germany
Space: Restaurant
Products: SB 38 Bar Stool

Tingbjerg Library
Location: Copenhagen, Denmark
Space: Library and Culture House
Products: SE 68 SU Stackable Chair



Hotel Brummel
Location: Barcelona, Spain
Space: Hotel
Products: SE 18 Folding Chair





PZN Office
 Location: Warsaw, Poland
 Space: Office
 Products: SE 68 Multipurpose Chair



Engel & Völkers Headquarters
 Location: Hamburg, Germany
 Space: Office
 Products: SNG 197 Swivel Chair

Be a Lion
 Location: Madrid, Spain
 Space: Office
 Products: SE 68 Chair



The Klub Kitchen
 Location: Berlin, Germany
 Space: Restaurant
 Products: SE 42 3-Legged Chair





1 SE 68 Multipurpose Chair

Egon Eiermann, 1951
Until today Eiermann's SE 68 is unique in its minimalist design and its seating comfort. A tubular steel frame in conjunction with an "organically" shaped seat and backrest made of moulded wood – the SE 68 was the earliest model in Germany in this combination of materials. To give furniture a "human dimension", that was Egon Eiermann's goal – and anyone who has ever sat on his SE 68 knows that hardly anyone lived up to this aim as much as the self-confessed perfectionist himself.

3 SB 68 Bar Chair

In their typical simplicity, the four-legged stools impress both with their stability and their perfect design. The SB 68 provides an alternative to the SB 38 – an elegant bar stool with backrest which is very comfortable.

2 SE 68 SU Stackable Chair

The multi purpose stacking chair. Its distinctive shape, the undeniable effect in the room and of course the typical Eiermann seating comfort make the stackable version of the SE 68 one of the greatest in terms of hall seating. Discreet yet with an incredible presence, the SE 68 SU develops its different character in all kinds of interiors just as if it were individually designed and developed for just this room, this hall, this building. In all kinds of interiors, it seems to have just the impact and expressiveness that transforms the overall composition into this one perfect unity.

4 SE 42 3-Legged Chair

Egon Eiermann, 1949
A chair whose frame, seat and back consist completely of moulded wood was to be the first production furniture item jointly developed by Egon Eiermann and Wilde+Spieth. The SE 42 is a three-legged wooden chair which stands out from the masses thanks to its distinctive lines and exclusive workmanship.



5 SE 18 Foldable Chair

Egon Eiermann, 1952
The folding chair for the discerning customer convinces with its minimalistic and exciting design, solid construction, high functionality and low space requirement during storage. Represented at the Museum of Modern Art in New York since 1953, at the College of Design in Ulm since 1955, and at the World Exposition in Brussels in 1958 it claims its place in modern design history. Meanwhile, after more than 60 years, it has convincingly passed the practical test too, while losing none of its original charm.

7 S 197 R20 Swivel Chair

The universal tool for the creative. The original concept, adapted to the human body, functions reduced to the bare minimum, sustainability of the materials and the clear language of form unchanged over the last years.

6 SBG 197 R Swivel Chair

The universal tool for the creative. The original concept, adapted to the human body, functions reduced to the bare minimum, sustainability of the materials and the clear language of form unchanged over the last years.

8 SBG 41 Swivel Chair

Egon Eiermann, 1951
The universal tool for the creative. The original concept, adapted to the human body, functions reduced to the bare minimum, sustainability of the materials and the clear language of form didn't change the last years.

1



2



5



6



3



4



1 S 38 S/1 Stackable Stool

In their typical simplicity, the four-legged stools impress both with their stability and their perfect design. The stackable stool S 38 S/1 convinces with its versatile, adaptable and robust nature.

3 S 193 R20 Swivel Stool

The universal geniuses in many fields of work. The multitasking swivel and roller stools are impressive in their versatility and variety. Tried and tested in laboratories, clinics, research institutes, schools, museums, at doctors, opticians, pharmacies, from tough commercial applications to the favourite stool in the home kitchen or at the piano, the uses for the S 193 R are almost limitless. Mobile on castors, stable on glides, steady on four legs, natural wood or in colour, upholstered in fabric, synthetic or natural leather, always just the way you need it.

2 SB 38 Bar Stool

In their typical simplicity, the four-legged stools impress both with their stability and their perfect design.

4 SBG 43 Swivel Stool

Egon Eiermann, 1951

The universal geniuses in many fields of work. The multitasking swivel and roller stools are impressive in their versatility and variety. Tried and tested in laboratories, clinics, research institutes, schools, museums, at doctors, opticians, pharmacies, from tough commercial applications to the favourite stool in the home kitchen or at the piano, the uses for the SBG 43 are almost limitless.

5 SE 330 Coffee Table

Egon Eiermann, 1952

An elegant table – simple 4-leg tubular steel frame that stands out with its successful combination of practicality and lightness. Originally designed by Eiermann only as a table matching the chair suitable for the SE 68, the range of applications of the SE 330 models has meanwhile expanded significantly.

6 SE 330 Couch Table

Egon Eiermann, 1952

An elegant table – simple 4-leg tubular steel frame that stands out with its successful combination of practicality and lightness. Originally designed by Eiermann only as a table matching the chair suitable for the SE 68, the range of applications of the SE 330 models has meanwhile expanded significantly.

Upholstery

We offer upholstery for seat and/or backrest. (Below: upholstery, seat only) Choose from our pre-selected palette of textiles, leather, or faux leather. Custom fabrics on request.

Stained Colours

Our standard offering for colour is stained beech wood. We only use environmentally suitable water-based stains. Our colour palette is selected to complement the natural materials we use and also complement each other.

Stackable

The SE 68 SU chair is stackable up to eight chairs. The SE 68 SU chair is also available with armrests and upholstery. In upholstered version stackable with stacking board. With armrests stackability is limited to four chairs.



Bar Chair

In two heights, 66 cm and 81 cm, the bar chair offers the same comfort as the SE 68 chair for the kitchen counter or at the bar. Our bar chairs can also be customized with upholstery.

Armrests

We offer armrests for added comfort. The armrests are stained, lacquered, or natural wood according to the chair.











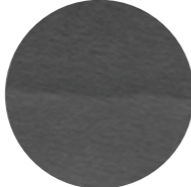

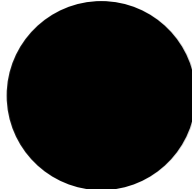

Lacquered Colours

Our white chairs and white stools come with a high quality, matte lacquered finish. We also offer a black lacquered finish for our products.





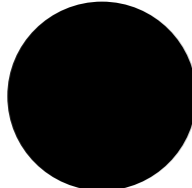

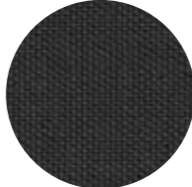
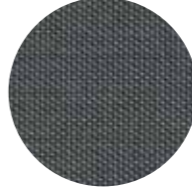

Wood Veneers

We offer four wood veneers. Beech is our standard veneer. Our premium veneers are oak, ash and walnut. All veneers we use are sourced from sustainable sources.

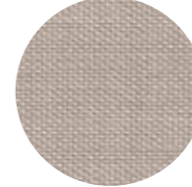
Colours & Wood Veneers

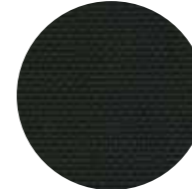
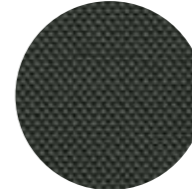
Stained Colours	 Black RAL 9005	 Graphite RAL 7024	
	 Cobalt Blue RAL 5013	 Rosé RAL 3012	 Blood Orange RAL 2002
	 Yellow RAL 1021	 Light Grey RAL 7047	
Lacquered Colours	 Black RAL 9005	 White RAL 9003	 White with wooden structure RAL 9003
Wood Veneers	 Beech	 Ash	
	 Oak	 Walnut	
Thermopal Uni	 Black	 White	

Textiles

Topia by Rohi	 Ebony	 Lanoso
	 Graphit	 Chrom
	 Angora	 Snow
Novum by Rohi	 Ebony	 Lanoso
		 Snow
Extreme by Camira		 Havana
		 Black
Advantage by Camira		 Black

Product Details



Product Details



1 Custom Colours

In addition to our standard colours, special colours for wooden parts and frames are possible for an additional charge. Give us a RAL colour for this or provide us with a stain sample of the respective wood type. Wilde + Spieth works environmentally friendly only with water-based stains. Wood is a natural product, so there may be colour deviations.

2 Fabrics

You have the option of choosing between two upholstery options: screw-on cushions for the seat and screw-on cushions for the seat and back

We recommend the fabrics from Rohi or Camira as upholstery fabrics. You will find a suitable selection of colours on page 49. It is also possible to choose from the entire range of Rohi, Camira and other manufacturers of your choice. Price on request.

3 Lacquered Colours

White chairs and stools are only available with a lacquered finish. Lacquer prevents the wooden parts from yellowing naturally over time and guarantees a long-term, consistent colour impression. The white lacquered version with a visible wood structure is now also available.

4 Frame Colours

Steel frames are available in chrome, matt black and satin finish. Black frames are smoothly powder-coated.

5 Glides and Casters

For the models S 197 R20 and S 193 R20, we also offer glides instead of casters. For the models SE 68, SE 68 SU, SB68, SB 38 and S 38 S/1 we offer a variety of glides for different surfaces.

Specifications

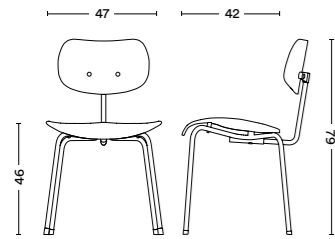

SE 68 Multipurpose Chair
Egon Eiermann, 1951
Material: 4-legged tubular steel frame (Ø 18 x 2 mm), moulded seat and backrest of laminated wood veneer
Stained colours: black, graphite, cobalt blue, rosé, blood orange, yellow, light grey
Lacquered colours: white, black
Weight: approx. 5 kg

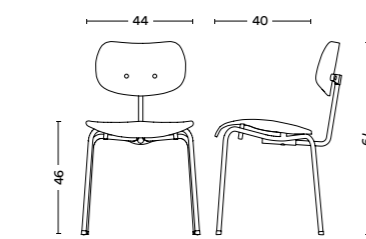

SE 68 SU Stackable Chair
Material: 4-legged tubular steel frame (Ø 18 x 2 mm), moulded seat and backrest of laminated wood veneer. The model is identical to SE 68 but with smaller seat and steeper leg placement to be stackable.
Stained colours: black, graphite, cobalt blue, rosé, blood orange, yellow, light grey
Lacquered colours: white, black
Weight: approx. 5 kg

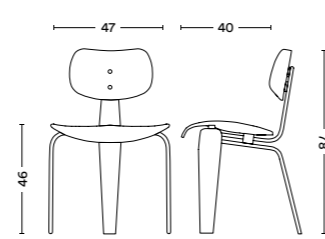

SE 42 3-Legged Chair
Egon Eiermann, 1949
Material: Curved wooden chair, 3-legged, with contoured wooden beech frame.
Stained colours: black, custom colours on request
Weight: approx. 5 kg

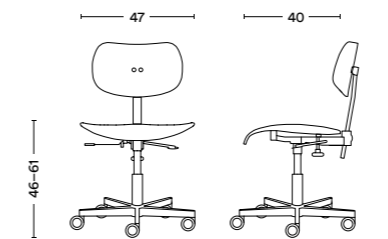

S 197 R20 Swivel Chair
Material: Swivel chair with aluminium frame. Moulded seat and backrest of laminated wood veneer.
Adjustments: Seat height adjustment, Seat tilt adjustment, back height adjustment
Stained colours: black, graphite, cobalt blue, rosé, blood orange, yellow, light grey
Lacquered colours: white, black
Weight: approx. 10 kg

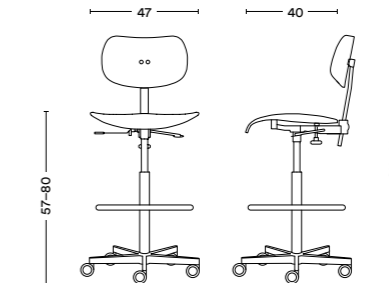

S 197 R20 Swivel Chair (Bar)
Material: Swivel chair with aluminium frame. Moulded seat and backrest of laminated wood veneer.
Adjustments: Seat height adjustment, Seat tilt adjustment, back height adjustment
Stained colours: black, graphite, cobalt blue, rosé, blood orange, yellow, light grey
Lacquered colours: white, black
Weight: approx. 12 kg

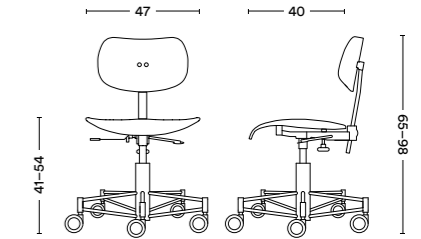

SBG 197 R Swivel Chair
Material: Swivel chair with Brussels frame. Moulded seat and backrest of laminated wood veneer.
Adjustments: Seat height adjustment, Seat tilt adjustment, back height adjustment
Stained colours: black, graphite, cobalt blue, rosé, blood orange, yellow, light grey
Lacquered colours: white, black
Weight: approx. 10 kg

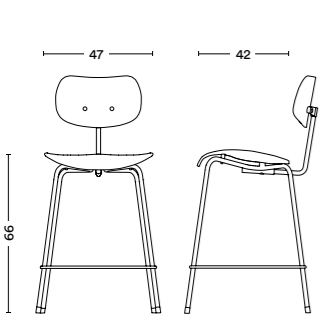

SE 68 Bar Chair
Material: 4-legged tubular steel frame with all-round foot ring (Ø 18 x 2 mm), moulded seat and backrest of laminated wood veneer
Stained colours: black, graphite, cobalt blue, rosé, blood orange, yellow, light grey
Lacquered colours: white, black
Weight: approx. 10 kg

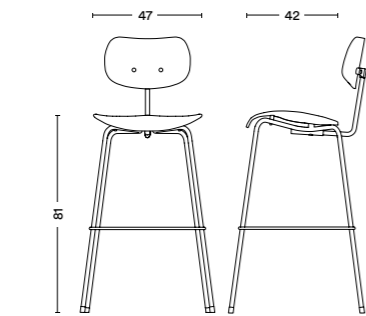

SE 68 Bar Chair
Material: 4-legged tubular steel frame with all-round foot ring (Ø 18 x 2 mm), moulded seat and backrest of laminated wood veneer
Stained colours: black, graphite, cobalt blue, rosé, blood orange, yellow, light grey
Lacquered colours: white, black
Weight: approx. 10 kg

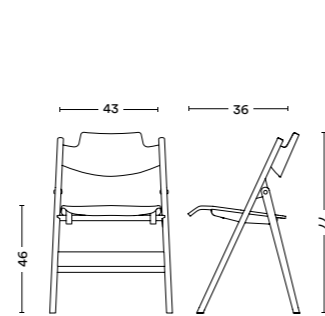

SE 18 Foldable Chair
Egon Eiermann, 1952
Material: Wooden folding chair with solid beech frame and tapered legs. Seat folds upwards when chair is folded. Horizontally stackable.
Stained colours: black, custom colours on request
Weight: approx. 5 kg

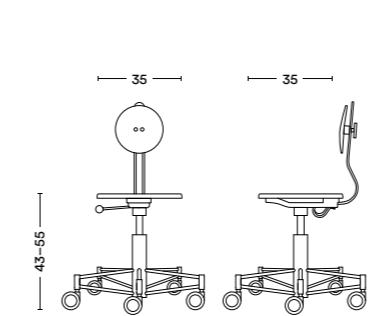

SBG 41 Swivel Chair
Material: Swivel chair with Brussels frame. Seat of laminated beech veneer. Backrest support moulded.
Adjustments: Seat height adjustment, back height adjustment
Stained colours: black, graphite, cobalt blue, rosé, blood orange, yellow, light grey
Lacquered colours: white, black
Weight: approx. 9 kg

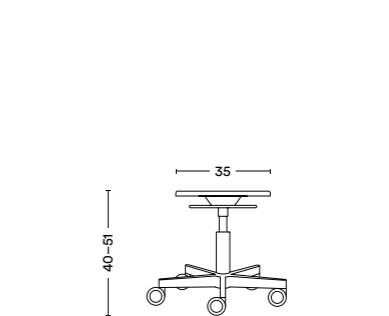

S 193 R20 Swivel Stool
Egon Eiermann, 1951
Material: Swivel stool with aluminium frame. Solid wood seat.
Adjustments: Seat height adjustment through revolving adjusting ring.
Stained colours: black, graphite, cobalt blue, rosé, blood orange, yellow, light grey
Lacquered colours: white, black
Weight: approx. 7 kg

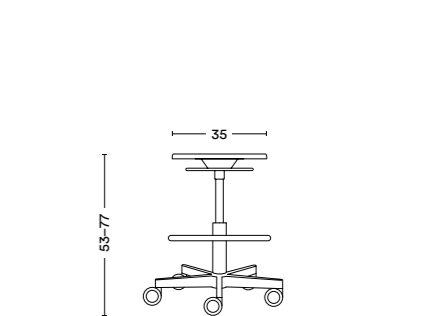

S 193 R20 Swivel Stool (Counter)
Egon Eiermann, 1951
Material: Swivel stool with aluminium frame. Solid wood seat.
Adjustments: Seat height adjustment through revolving adjusting ring.
Stained colours: black, graphite, cobalt blue, rosé, blood orange, yellow, light grey
Lacquered colours: white, black
Weight: approx. 9,5 kg

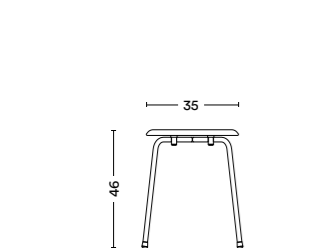

S 38 S/1 Stackable Stool
Material: 4-legged stool with tubular steel frame (Ø 18 x 2 mm). Solid wood seat.
Stained colours: black, graphite, cobalt blue, rosé, blood orange, yellow, light grey
Lacquered colours: white, black
Weight: approx. 2.5 kg

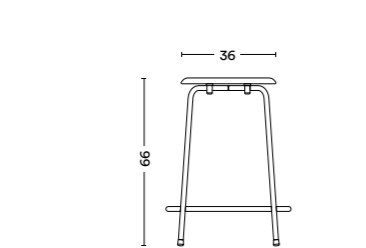

SB 38 Bar Stool (Counter)
Material: 4-legged stool with tubular steel frame (Ø 18 x 2 mm). Solid wood seat.
Stained colours: black, graphite, cobalt blue, rosé, blood orange, yellow, light grey
Lacquered colours: white, black
Weight: approx. 5 kg

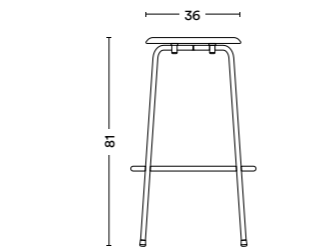

SB 38 Bar Stool
Material: 4-legged stool with tubular steel frame (Ø 18 x 2 mm). Solid wood seat.
Stained colours: black, graphite, cobalt blue, rosé, blood orange, yellow, light grey
Lacquered colours: white, black
Weight: approx. 5 kg

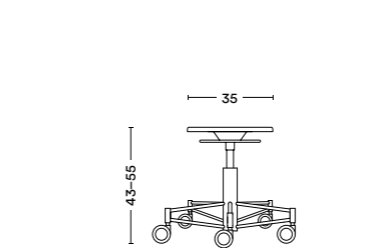

SBG 43 Swivel Stool
Egon Eiermann, 1951
Material: Swivel stool with Brussels frame. Solid wood seat.
Adjustments: Seat height adjustment through revolving adjusting ring.
Stained colours: black, graphite, cobalt blue, rosé, blood orange, yellow, light grey
Lacquered colours: white, black
Weight: approx. 7 kg

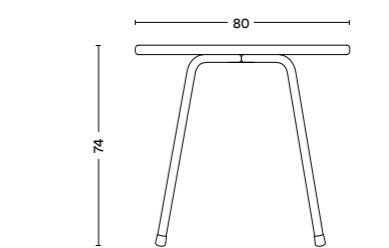

SE 330 Coffee Table
Egon Eiermann, 1952
Material: Tubular steel frame (Ø 22 x 2 mm) with round table top.
Stained colours: black, graphite, cobalt blue, rosé, blood orange, yellow, light grey
Lacquered colours: white, black

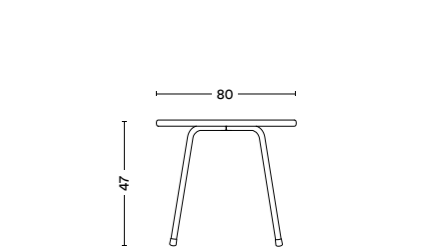

SE 330 Couch Table
Egon Eiermann, 1952
Material: Tubular steel frame (Ø 22 x 2 mm) with round table top.
Stained colours: black, graphite, cobalt blue, rosé, blood orange, yellow, light grey
Lacquered colours: white, black

Important Remarks

Orders

Orders are scheduled for processing as soon as all necessary details, e.g. materials and dimensions, are agreed upon. Posted fabric and colour samples have to arrive in time. Adjustments to already placed orders are possible, given proper notification on our side. Additional costs caused have to be charged to your order.

Terms of Delivery

Terms of delivery given in the Wilde + Spieth confirmation of order are to be understood as approximate dates EXW. Delivery ex works, Germany. Warranty within our general terms of delivery and payment.

Casters

Casters are blocked according to load. For soft floors (e.g. carpets) you require hard casters and for hard floors soft casters (with a lighter middle ring) to suit DIN 4551. Casters for hard floors are standard.

Open-Cell Stain

With wooden parts staining is possible for an additional charge. Wilde + Spieth operates with environmentally suitable water-based stains. Information according to RAL-chart of a stained sample of the ordered wood is necessary. Wood is a natural product therefore discolouring may occur. Our stain is resistant to cleaning agents.

Posted Fabric

We upholster with your fabric. Please send us the material free of charge. In case the material does not arrive in time, the confirmed delivery date might have to be postponed. The stated material supply is to be understood without addition due to rapport. Wilde + Spieth is not to be held accountable for the quality and processing. Please make sure the fabric is at least 130 cm wide, excluding the weaving edges. Please send a sufficiently large piece of cloth to ensure trial upholstery in regards to rapport size and direction.

Please make sure that the fabric without selvage is at least 130 cm wide.

Leather

Leather is a natural product. Discolouring, wrinkling and structural irregularities may occur and present no deterioration of quality thus are not subject to reclamation.

Custom Made Models

We offer custom made models, such as special sizes or styles or special types of wood. We reserve the rights of changed constructions and prices.

We hold the right for design changes.

Authenticity

Wilde + Spieth is the exclusive licensee and the only authorized manufacturer of the following products:
SE 68, SE 18, SE 42, SE 40, SE 41, SE 43, SBG 41, SBG 43, S 319, SE 330, 711 1301, 710 1200
All of the designs listed above are protected by copyright. This list only contains designs that are currently in production.

Wilde + Spieth
Designmöbel GmbH & Co. KG
Röntgenstraße 1/1
73730 Esslingen, Germany
T +49 711 351 303-0
F +49 711 351 303-11
E info@wilde-spieth.com
www.wilde-spieth.com
www.instagram.com/wildespieth

Thank you

Museum of Modern Literature (Marbach), SMOW
Stuttgart, NYTA Lighting, Friends of Friends,
Friendsspaces

Creative Direction & Graphik Design

Tilgner-Kempf

Photografie

Fabian Frinzel (4, 6, 7, 10, 11, 12, 17, 19, 22, 24, 25, 26, 28, 36, 39), Aimee Shirley (8, 9, 15, 20),
Tilgner-Kempf (16, 18, 23, 27, 29, 30, 37, 46, 50, 51),
Jules Villbrandt (14), Amos Schliack (34), Rasmus
Hjortshøy (38), Helene Høyer Mikkelsen (38),
Felix Schöppner (39), PION Studio (40), Christoph
Piladelphia (41), Pablo Gómez-Ogando (41),
Klemens Renner (41)

Text

Anna Dorothea Ker (3, 32, 38)

Printing

Pfizer, Renningen

www.wilde-spieth.com

Instagram: @wildespieth

Made in Germany